

**RIGHT ANGLE PLUG CRIMP TYPE**

**R214.186.000**

**CABLE 2.6/75**

Series : SMZ

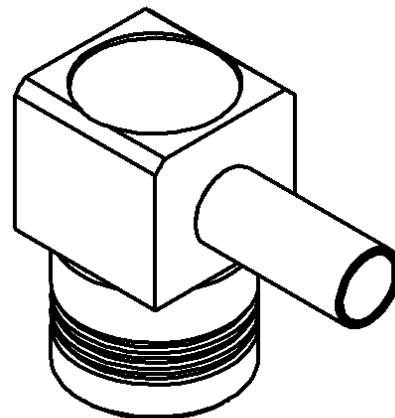
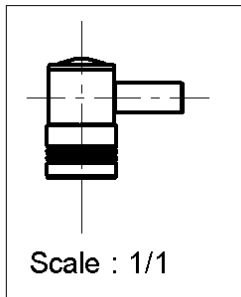
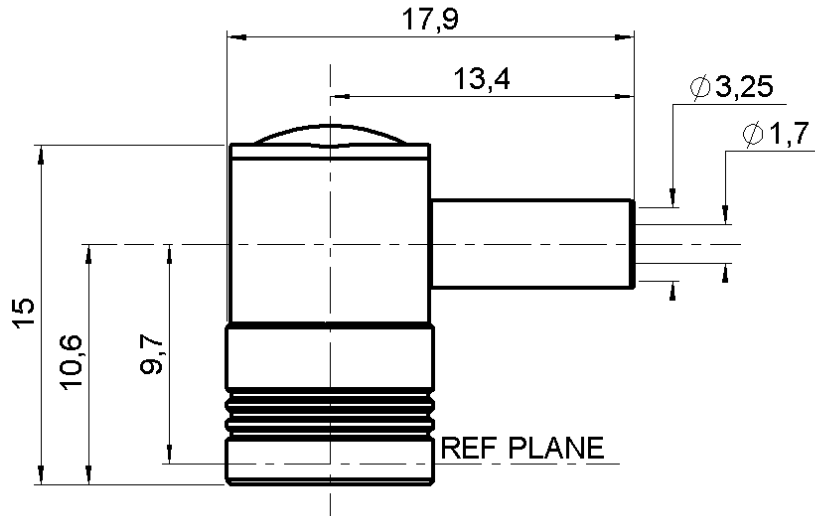

All dimensions are in mm.

COMPONENTS	MATERIALS	PLATINGS (µm)
BODY	BRASS	GOLD 0.2 OVER NICKEL 2
CENTER CONTACT	BERYLLIUM COPPER	GOLD 1.3 OVER NICKEL 2.54 OVER COPPER
OUTER CONTACT	BERYLLIUM COPPER	3
INSULATOR	PTFE	GOLD 0.5 OVER NICKEL 2
GASKET	-	
OTHERS PARTS	BRASS	
-	-	GOLD 0.2 OVER NICKEL 2
-	-	-
-	-	-

Issue : 9908 B

In the effort to improve our products, we reserve the right to make changes judged to be necessary.



**RIGHT ANGLE PLUG CRIMP TYPE**

**R214.186.000**

**CABLE 2.6/75**

Series : SMZ

**PACKAGING**

Standard	Unit	Other
<b>100</b>	<b>'W' option</b>	<b>Contact us</b>

**SPECIFICATION**

**CABLE ASSEMBLY**

**ELECTRICAL CHARACTERISTICS**

Stripping	a	b	c	d	e	f
mm	3.00	6.90	13.7	0.00	10.7	0.00

Impedance		<b>75</b> Ω
Frequency		<b>0-2.4</b> GHz
VSWR	<b>1.25 +</b>	<b>0.000</b> x F(GHz) Maxi
Insertion loss		<b>0.2</b> √F(GHz) dB Maxi
RF leakage	- (	<b>60</b> - F(GHz) dB mini
Voltage rating		<b>250</b> Veff Maxi
Dielectric withstanding voltage		<b>750</b> Veff mini
Insulation resistance		<b>500</b> MΩ mini

Assembly instruction : **Crimp 05**

Recommended cable(s)  
RG 179  
RG 187

Cable retention  
- pull off **120** N mini  
- torque **NA** N.cm

**MECHANICAL CHARACTERISTICS**

**TOOLING**

Center contact retention		
Axial force – Mating end	<b>10</b>	N mini
Axial force – Opposite end	<b>10</b>	N mini
Torque	<b>NA</b>	N.cm mini

Part Number	Description	Hexagon
.	.	.
R282.211.000	CRIMPING TOOL	3.25
R282.235.003	CRIMPING DIES	3.25
R282.293.000	CRIMPING TOOL	-

Recommended torque		
Mating	<b>NA</b>	N.cm
Panel nut	<b>NA</b>	N.cm
Clamp nut	<b>NA</b>	N.cm
A/F clamp nut	<b>0.000</b>	mm

**OTHERS CHARACTERISTICS**

Mating life	<b>250</b>	Cycles mini
Weight	<b>0.000</b>	g

**ENVIRONMENTAL**

Operating temperature	<b>-55/+155</b>	° C
Hermetic seal	<b>NA</b>	Atm.cm3/s
Panel leakage	<b>NA</b>	

Issue : 9908 B

In the effort to improve our products, we reserve the right to make changes judged to be necessary.

